

## 特點/Features

- 材質：不銹鋼/Stainless steel
- 固定方式：Fixed mode：Set screw type
- 表面處理：陽極處理/Anodizing standard white
- 一體成型/One-body shape.
- 零背隙/Zero backlash
- 剛性大/High rigid
- 輕巧、無污染/Light and landy、zero contamination
- 偏角誤差較佳/High deflection
- 適合用於譯碼器、小馬力傳動、高精度傳動/  
It fits to Encoder、transfer of low horsepower



## 選購型號/Order NO.

CS-CTS- $(\varnothing D)$ - $(\varnothing d1)$ x $(\varnothing d2)$

NO.	外徑/Diameter	NO.	孔徑/Aperture(Min)	NO.	孔徑/Aperture(Max)
12	∅ 12mm	3	∅ 3mm	6	∅ 6mm
16	∅ 16mm	4	∅ 4mm	8	∅ 8mm
20	∅ 20mm	5	∅ 5mm	10	∅ 10mm
25	∅ 25mm	6	∅ 6mm	12	∅ 12mm
32	∅ 32mm	6	∅ 6mm	14	∅ 14mm
40	∅ 40mm	8	∅ 8mm	20	∅ 20mm
50	∅ 50mm	12	∅ 12mm	25	∅ 25mm
63	∅ 63mm	15	∅ 15mm	35	∅ 35mm

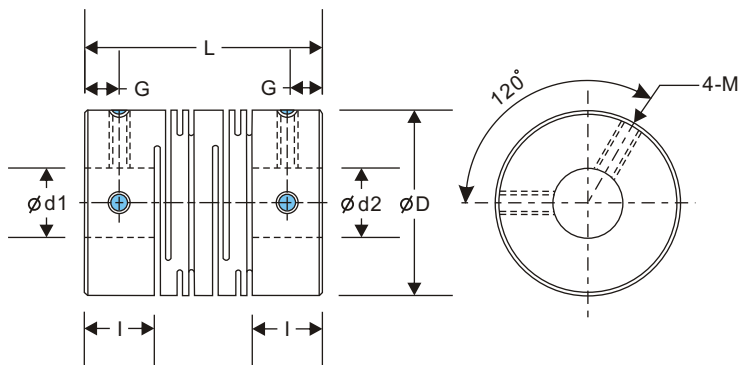

## 規格/Specifications

TYPE	Rated Torque 一般扭力 (N.m)	Max. Torque 最大扭力 (N.m)	Max. Rotational Frequency 最高回轉數 (min <sup>-1</sup> )	Moment* of Inertia 慣性 (kg·m <sup>2</sup> )	Errors of Eccentricity 容許偏心 (mm)	Errors of Angularity 容許偏角 (°)	Errors of Shaft End-Play 容許軸向位差 (mm)
CS-CTS-12	0.3	0.6	32000	$2.1 \times 10^{-7}$	0.10	2	±0.3
CS-CTS-16	0.5	1	24000	$8.4 \times 10^{-7}$	0.10	2	±0.3
CS-CTS-20	1	2	19000	$2.4 \times 10^{-6}$	0.10	2	±0.3
CS-CTS-25	2	4	15000	$6.8 \times 10^{-6}$	0.15	2	±0.4
CS-CTS-32	3.5	7	12000	$2.6 \times 10^{-5}$	0.15	2	±0.5
CS-CTS-40	8	16	9600	$8.7 \times 10^{-5}$	0.20	2	±0.5
CS-CTS-50	15	30	7700	$2.7 \times 10^{-4}$	0.20	2	±0.5
CS-CTS-63	35	70	6100	$8.4 \times 10^{-4}$	0.20	2	±0.5

## 外型尺寸/Dimensions (Unit:mm)

TYPE	D	I	L	G	M	d1xd2 標準孔徑 公差(H8)		Mass* 質量(g)
						Min	Max	
CS-CTS-12	12	5	18.5	2.5	M2.5	3	6	14
CS-CTS-16	16	6.5	23	3	M3	4	8	28
CS-CTS-20	20	7.5	26	3	M4	5	10	45
CS-CTS-25	25	8.5	31	4	M4	6	12	95
CS-CTS-32	32	12	41	6	M5	6	14	220
CS-CTS-40	40	15	56	8.5	M5	8	20	350
CS-CTS-50	50	18	71	10.5	M6	12	25	700
CS-CTS-63	63	22	90	13	M8	15	35	1300