

# SetPro

## INSTRUCTION MANUAL FOR NT-+ FUZZY PID

### FRONT PANEL DESCRIPTION

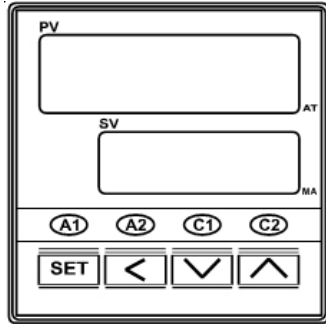

- (1) PV - Process Value
- (2) SV - Setting Value
- (3) AT - Auto tuning LED
- (4) MA - Manual mode LED
- (5) A1 - Alarm 1 LED
- (6) A2 - Alarm 2 LED
- (7) C1 - Control 1 LED
- (8) C2 - Control 2 LED

1. **SET** - SET KEY. Press once to access the next programmable parameter. Press this key for 5 seconds to reset alarm timer.
2. **▲** - UP KEY. Press to increase the set point or parameter value.
3. **▼** - DOWN KEY. Press to decrease the set point or parameter value.
4. **◀** - SHIFT KEY. Press the shift key for 5 seconds to execute Auto Tune process (Yes. 1 mode). To abort the Yes. 1 Auto Tune process, press the shift key for 5 seconds.
5. **SET ▲** - Press the SET and UP keys once to return the normal operation.
6. **SET ◀** - LEVEL KEY. Press the SET and SHIFT keys simultaneously for 5 seconds to select programming level, then press SET key to enter this level.
7. **▲ ▼** - Press the UP and DOWN keys simultaneously for 5 seconds to access "LnLo" and "LnHi" parameters.

### PANEL CUTOUT

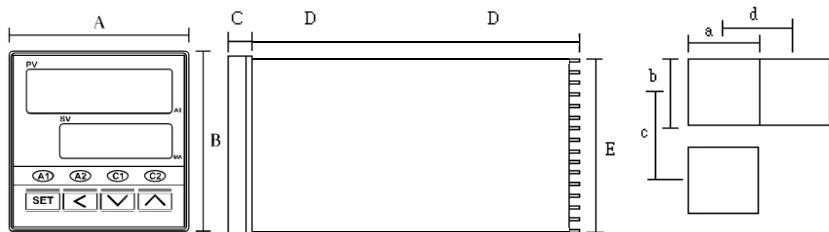

Model	A	B	C	D	E	a	b	c	d
NT-486 <sup>+</sup>	48	48	6	100	45	45+0.5	45+0.5	60	48
NT-726 <sup>+</sup>	72	72	9	80	67	68+0.5	68+0.5	90	72
NT-496 <sup>+</sup>	48	96	9	80	91	45+0.5	92+0.5	120	48
NT-946 <sup>+</sup>	96	48	9	80	45	92+0.5	45+0.5	48	120
NT-966 <sup>+</sup>	96	96	10	80	91	92+0.5	92+0.5	120	96

(Unit:mm)

### WIRING DIAGRAM

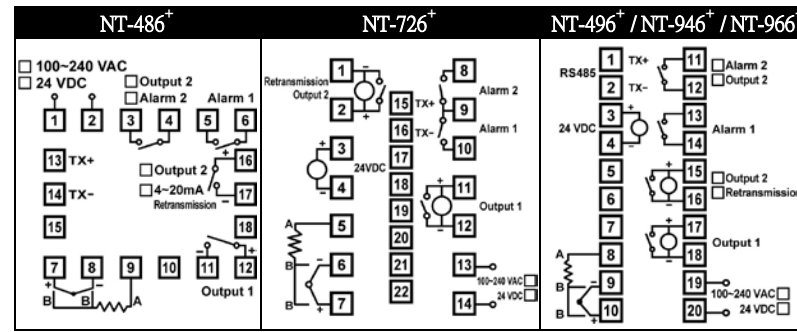

### WIRING PRECAUTIONS

1. Before wiring, verify the controller label for correct model number and option.
2. For thermocouple input, use the appropriate compensation wire. And note the polarity of input signal.
3. To avoid noise induction, keep input signal wire away from instrument power line, load lines and power lines of other electric equipment.

### PROGRAMMING LEVEL PARAMETERS

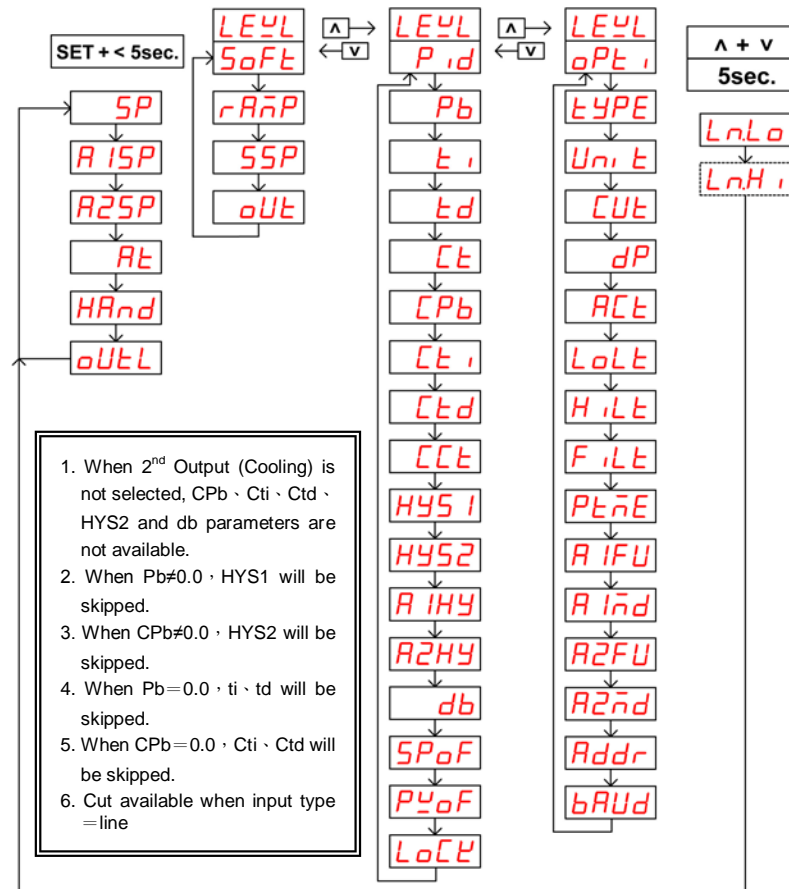

### PARAMETER DESCRIPTION :

LEVEL Selection  
Press **SET** **◀** keys for at least 5 seconds to access Soft Level. Use **▲** or **▼** key to select programming level. Then press **SET** key to enter this level.

LEVEL	Description
SoFt	SoFt Level
P id	PID Level
oPt ,	Option Level

### USER LEVEL

Code	Description	Range	Default
SP	Set point value of control	LoLt - HiLt	500
A1SP	Alarm 1 set point value/Timer set value while A1FU is set to T.on or T. off, the unit can be HH.MM or MM.SS. It depends on the "P.tnE" parameter.	-1999 - 9999/00.00-99.59	10
A2SP	Alarm 2 set point value/ Timer set value while A2FU is set to T.on or T. off, the unit can be HH.MM or MM.SS. It depends on the "P.tnE" parameter.	-1999 - 9999/00.00-99.59	10
At	no : Auto-tuning is disable YES.1 : Standard type auto-tuning. Autotune PV is compared wit SV during auto tuning. YES.2 : Low PV type auto-tuning. PV is compared with SV-10%FS during Auto-tuning.	no YES.1 YES.2	no
HRnd	no : Disable the manual mode Manual control YES : Enable the manual mode.	no YES	no
oUtl	Output percentage. Adjustable when "Hand" is set to "Yes"	-100.0 - 100.0	100.0

### SOFT LEVEL

Code	Description	Range	Default
rAnP	Ramp rate for the process value to limit an abrupt Change of process.( °C/min.)	0 - 9999 (0.0 - 999.9)	0.0
SSP	Set point value of soft-start	LoLt - HiLt	0
oUt	Output percentage of soft-start	0.0 - 100.0	100.0

### PID LEVEL

Code	Description	Range	Default
Pb	Proportional band variable. Set to 0.0 for ON/OFF control mode.	0.0-300.0%	10.0
ti	Integral time (Reset). This value is automatically calculated by activating the Autotune function. If desired, the user can later adjust this parameter to better suit the application. When PB=0.0, this parameter will be not available. When set to zero, Pb & td ≠ 0 for PD control.	0-3600sec	240
td	Derivative (Rate). This value is automatically calculated by activating the Auto tune function. If desired, the user can later adjust this parameter to better suit the application. When PB=0.0, this parameter will be not available. When set to zero, Pb & td ≠ 0 for PI control.	0-900sec	60
Ct	Proportional cycle time of output 1.	0-100sec	15
CPb	Proportional band variable for secondary control output (cooling). Set 0.0 for ON/OFF.	0.0-300.0%	10.0
Cti	Integral time for secondary control output. When CPb=0.0, this parameter will be not available. When set to zero, CPb & Ctd ≠ 0 for PD control.	0-3600sec	240
Ctd	Derivative time for secondary control output. When CPb=0.0, this parameter will be not available. When set to zero, CPb & Cti ≠ 0 for PI control.	0-900sec	60
CCt	Proportional cycle time of output 2.	0-100sec	15
HYS1	Hysteresis for ON/OFF control on output 1.	0-2000 (0.0-200.0)	1
HYS2	Hysteresis for ON/OFF control on output 2.	0-2000 (0.0-200.0)	1
A1HY	Hysteresis of alarm 1.	0-2000	1
A2HY	Hysteresis of alarm 2.	0-2000	1
db	Dead band value. This defines the area in which output 1 and output 2 are both active (negative value) or the area in which output 1 and output 2 are both inactive (positive value).	-1000-1000 (-100.0-100.0)	0
SPoF	Set point offset. This value will be added to SV to perform control. It mainly used to eliminate offset error during P control.	-1000-1000 (-100.0-100.0)	0
PYoF	Process value offset. Permits the user to offset the PV indication from the actual PV.	-1000-2000 (-100.0-200.0)	0
LoCK	Parameter lock. This security feature locks out selected levels or single parameters prohibiting tampering and inadvertent programming changes.		

LEVEL	Description	Default
0000	All parameters are locked out.	
0001	Only SP is adjustable	
0010	Only USER level is adjustable	
0011	USER and PID levels are adjustable.	
0100	USER,PID,OPTI levels are adjustable.	
0101	USER,SOFT,PID,OPTI levels are adjustable.	
0101-0111	All parameters in all levels are opened.	
1000-1111	1000=0000,1001=0001, 1010=0010,1011=0011,1100=0100 but Output 2 is opened.	0100

## OPTION LEVEL

Code	Description	Range	Default
TYPE	Input type selection.		
	TYPE	RANGE( °C)	RANGE( °F)
	J	-50~1000	-58~1832
	K	-50~1370	-58~2498
	T	-270~400	-454~752
	E	-50~950	-58~1742
	B	0~1800	32~3272
	R	-50~1750	-58~3182
	S	-50~1750	-58~3182
	N	-50~1300	-58~2372
	C	-50~1800	-58~3272
D-PT	-200~850	-328~1562	
J-PT	-200~600	-328~1112	
LINE	-1999~9999		

Code	Description	Range	Default
Unit	Unit of process value OC : Degrees C. OF : Degrees F. ENG : Engineer unit for linear input.	OC OF ENG	°C

Code	Description	Range	Default
OUT	Used to specify the process value when linear input (type=line) signal is out of range. None= this function is not used. Lo = The process value will be limited to LoLt when input signal is lower than the scale range. Hi = The process value will be limited to HiLt when input signal is higher than the scale range. Lo.Hi = The process value will be limit within the range of LoLt to HiLt when input signal is out of scale.	nonE · Lo Hi · Hi.Lo	nonE

Code	Description	Range	Default
DP	Decimal point selection. 0000 : No decimal point. 000.0 : 0.1 resolution 00.00 : 0.01 resolution, used for linear input only. 0.000 : 0.001 resolution, used for linear input only. After change decimal point, please reconfirm the parameter.	0000 000.0 00.00 0.000	0000

Code	Description	Range	Default
ACT	Output 1 control action. REV : Reverse action for heating. DIR : Direct action for cooling.	REV DIR	REV

Code	Description	Range	Default
LoLt	Low limit of span or range. Set the low limit lower than the lowest expected SV and PV display.	Full range	0

Code	Description	Range	Default
HiLt	High limit of span or range. Set the high limit higher than highest expected SV and PV display.	Full range	1000

Code	Description	Range	Default
FiLt	Software filter.	0.0~99.9	10.0

Code	Description	Range	Default
PTnE	Time scale for timer alarm. HH:MM Hours:Minutes; mm:ss Minutes:Seconds	00.00~99.59	00.00

Code	Description	Range	Default
A1FU	Alarm 1 function. Refer to alarm function section for detail. If A1FU=None, it means alarm function is cancelled.	None, Hi, Lo, dif.H, dif.L, bd.Hi, bd.Lo, t.on, t.oFF	d i F H

Code	Description	Range	Default
A1nd	Alarm 1 mode. Refer to alarm mode section for detail.	none, Stdy, Lath, St.La	nonE

Code	Description	Range	Default
A2FU	Alarm 2 function. Refer to alarm function section for detail. If A2FU=None, it means alarm function is cancelled.	none, Hi, Lo, dif.H, dif.L, bd.Hi, bd.Lo, t.on, t.oFF	d i F L

Code	Description	Range	Default
A2nd	Alarm 2 mode. Refer to alarm mode section for detail.	none, Stdy, Lath, St.La	nonE

Code	Description	Range	Default
Addr	Address of controller when communication with master device.	0 - 255	1

Code	Description	Range	Default
BAUD	Communication baud rate. 2.4k=2400bps, 4.8k=4800bps, 9.6k=9600bps, 19.2k=19200bps	2.4k, 4.8k, 9.6k, 19.2k	9.6k

Code	Description	Range	Default
LnLo	Low Scale of Linear Input	-1999~9999(-199.9~999.9)	0.0
LnHi	High Scale of Linear Input	-1999~9999(-199.9~999.9)	100.0

## Scaling for Linear Input

- Press the UP and DOWN keys simultaneously for 5 seconds to access "LnLo" parameter.
- Adjust "LnLo" setting to correspond the low scale and after adjustment press **SET** key once to access "LnHi" parameter.
- Adjust "LnHi" setting to correspond the high scale and after adjustment press **SET** key once for normal operation.

## ALARM FUNCTION

### Select the alarm function

- nonE – Alarm action off.  
 Hi – Process high alarm with Form A contact  
 Lo – Process low alarm with Form A contact  
 diF.H – Deviation high alarm with Form A contact  
 diF.L – Deviation low alarm with Form A contact  
 bd.Hi – Deviation band high alarm with Form A contact  
 bd.Lo – Deviation band low alarm with Form A contact  
 t.on – On-timer with Form A contact  
 t.oFF – Off-timer with Form A contact
- b.noE – Alarm action off  
 b.Hi – Process high alarm with Form B contact  
 b.Lo – Process low alarm with Form B contact  
 b.diH – Deviation high alarm with Form B contact  
 b.diL – Deviation low alarm with Form B contact  
 b.bdH – Deviation band high alarm with Form B contact  
 b.bdL – Deviation band low alarm with Form B contact  
 b.ton – On-timer with Form B contact  
 b.toF – Off-timer with Form B contact

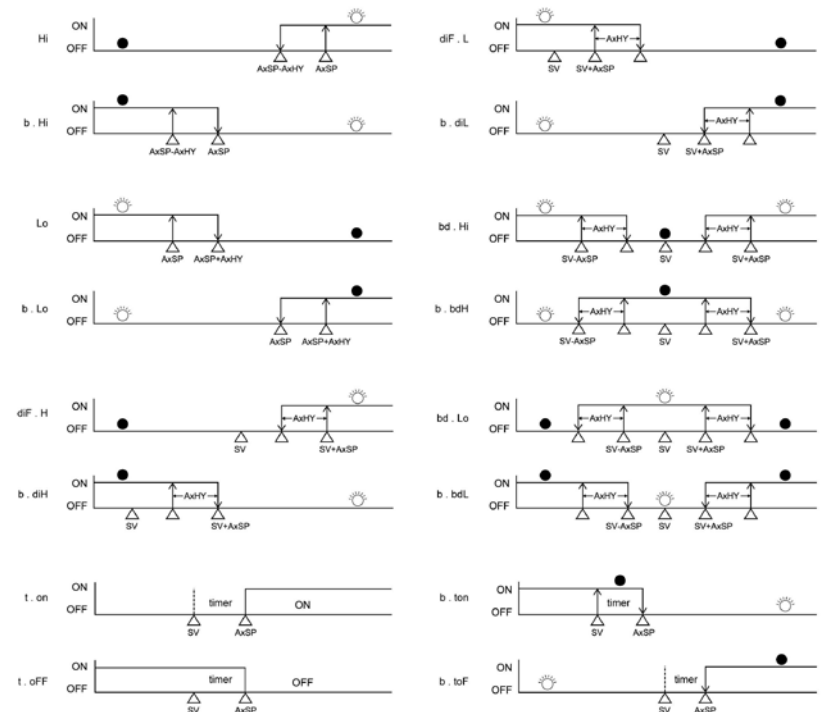

## ALARM MODE

A1MD/A2MD	DESCRIPTION
nonE	Normal alarm mode/ When timer function is selected, PV<SV timer function is not available.
Stdy	Standby mode When selected, in any alarm function, prevents an alarm on power on. The alarm is enabled only when the process value reach alarm set point. Also known as "Startup inhibit" and is useful for avoiding alarm trips during startup.
LATH	Latch mode. When selected, the alarm output and indicator latch as the alarm occurs. The alarm output and indicator will be energized even if the alarm condition has been cleared unless the power is shut off. When Timer function is selected, PV<SV timer function is available.
StLA	Standby and latch mode

## AUTOMATIC AND MANUAL OUTPUT CONTROL

Automatic control is the normal mode of controller operation. In automatic control mode the controller automatically adjust the control output percentage by PID algorithm so that the PV=SV. The PID parameter Pb, Ti and Td can be also calculated by Auto Tune procedure. Manual control allows the user to manually drive the output percentage from 0.0 to 100.0%. To access the manual mode, set the "HAnd" parameter to "YES", the rightmost decimal (MA) on SV display will flash. Then the "OUTL" parameter will display alternately "OUTL" and process value. The output percentage then can be adjusted by pressing UP or DOWN key. To abort the manual control just simply set the "HAnd" to "no".

## AUTO TUNE

In order to automatically set the PID parameter in PID level ("Pb" proportional band, "ti: integral time or reset and "td" derivative time or rate), first adjust the controller's set point to a value, which closely approximates your application. Set the "At" parameter to "YES.1" for standard type

auto tune or "YES.2" for low PV type auto tune. The right-most decimal point (AT) on the PV display begins flashing. The auto tune procedure will take two cycle oscillations. After that, the controller performs PID control with the "learned" PID value to verify the results. Finally the PID values will be entered into the nonvolatile memory and then start the Fuzzy enhanced PID control. The auto tune process can last from several minutes up to two hours, depending on the system's parameter. A time out error will occur if the auto tune process can not be completed within two hours, in this case, try to set the PID parameters manually.

To abort an auto tune process, simply set the "At" parameter to "no".

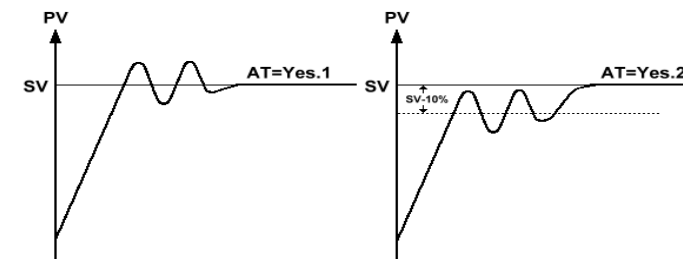

The controller can also be set to ON/OFF, PI, PD and P control mode. Set Pb = 0 for ON/OFF control mode. Set ti = 0 for PD control mode. Set td = 0 for PI control mode and ti, td = 0 for P control mode. The Hysteresis (dead band) of ON/OFF control can be set as follow:

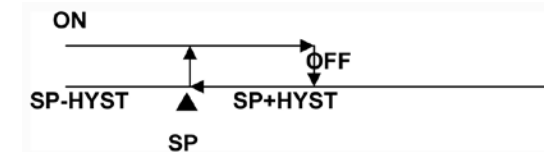

When the second control output (output 2) is equipped the proportional band of output 2 and dead band are defined as follow:

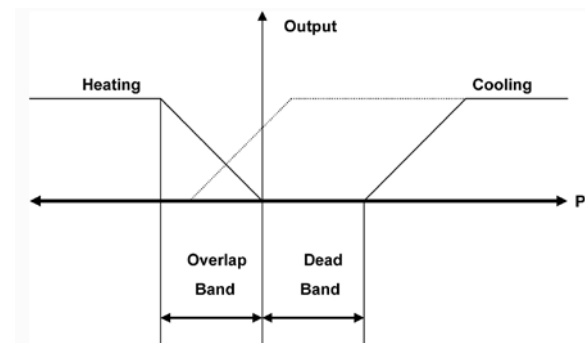

## ERROR MESSAGE AND TROUBLESHOOTING

Symptom	Probable	Solution
oPEn	-Sensor break error -Sensor not connected	-Replace sensor -Check the sensor is connected correctly
AdEr	-A/D converter damage	-Unit must be repaired or replaced. -Check for outside source of damage such as transient voltage spikes.
AtEr	-Auto tune time out error	Set Pb, ti, td manually.
Keypad no function	-Keypads are locked -Keypads defective	-Set "LoLk" to a proper value -Replace keypads
Process value unstable	-Improper setting of Pb, Ti, Td and CT	-Start AT process to set Pb, Ti, Td automatically -Set Pb, Ti, Td manually
No heat or output	-No heater power or fuse open -Output device defective or incorrect output used	-Check output wiring and fuse -Replace output device
All LED's and display not light	-No power to controller -SMPS failure	-Check power lines connection -Replace SMPS
Process Value changed abnormally	-Electromagnetic Interference (EMI) or Radio Frequency Interference (RFI)	-Suppress arcing contacts in system to eliminate high voltage spike sources. Separate sensor and controller wiring from "dirty" power lines. Ground heaters
Entered data lost	-Fail to enter data to EEPROM	-Replace EEPROM

\*

VERTEX 2013.5

VERTEX is constantly striving to improve its high-quality products, the information contained in this manual is subject to change without notice. Every precaution has been taken in the preparation of this manual.