

TG-RE-0315L

PRETA

Direct Current Tachometer generator

- Destination :**
- Industrial applications
 - Speed control and regulation
- Description :**
- New mechanical design with terminal box or cable
 - Magnetic circuit designed for standard industrial applications
 - Only with flange



DIAGRAM

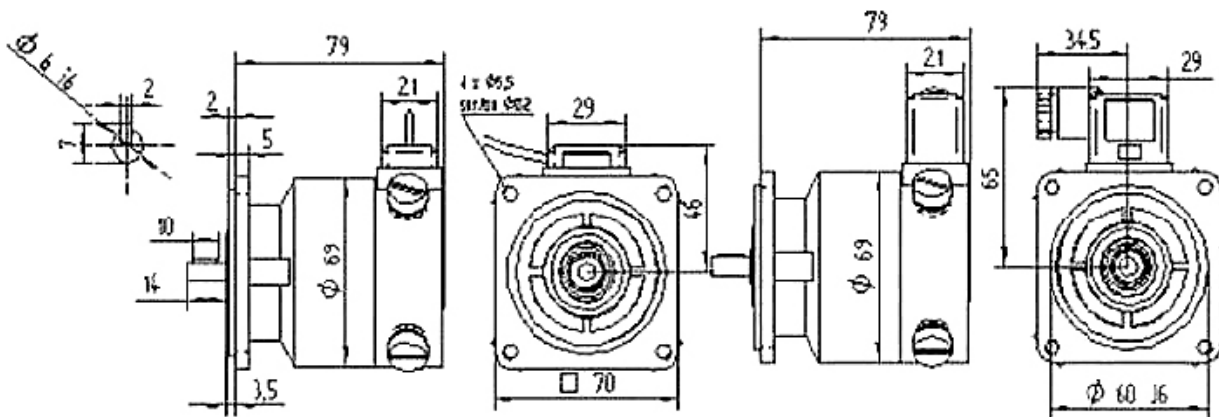

MAIN CHARACTERISTICS

DESIGNATION	SYMB	VALUE
Max. speed (mechanical)	n_m	8 000 rpm
Moment of inertia	J	0.62 Kg cm ²
No-load driving torque	M_r	0.4 N.cm
Max. radial shaft stress	F	0.3 (Ø 6)/1.0 (Ø 11) da N
Maximum E.M.F.	E_m	300 V
Maximum linearity error	ΔE	< 0,15 % E_T
Overall ripple rate (peak to peak)	ΔE_c	< 1 % E_c
Calibration precision	ΔE_o	$\pm 1.5 E_{T_o}$
E.M.F. temp. drift		
- Not compensated	ΔE_e	0.02 %/°C
- Compensated		
Time constant	C_t	0.2 ms
*Filter: Time constant		1 ms
Load current		3 mA
Speed		3 000 rpm

CONSTRUCTION DETAILS

Number of poles 2p	B (IEC 34-1)
Number of armature	-20/+80 °C
Number of collector blades	C_a (IEC 68-1)
Insulation class	IP 44 (IEC (34-5))
Direction of rotation:	reversible
Excitation: permanent magnets:	Alnico

Weight:	1 kg
----------------	-------------

MECHANICAL OPTIONS

Shaft ends and bearings

	MOUNTING SIDE		
	D (mm)	L (mm)	Bearings
Standard	6	14	12 x 28 x 8 ZZ
Max	11	30	12 x 28 x 8 ZZ

OPPOSITE MOUNTING SIDE

Bearings	8 x 22 x 7 ZZ
	8 x 22 x 7 ZZ

Various adaptors available for mounting devices on the rear of the tachometer generator.



Markings and polarity of terminals (cables) for counter-clockwise rotation, seen from the shaft.

A1 : +
A2 : -

TG-RE-0315L

Direct Current Tachometer generator

PRETA

ELECTRIAL OPTIONS

DESCRIPTION	SYMB	UNIT	VALUES						
			Min.						Max.
E.M.F. at 1 000 rpm	E_n	V	7	10	20	30	40	50	60
Voltage gradient	C_v	V/rpm	0.007	0.010	0.020	0.030	0.040	0.050	0.060
Armature resistance	R_a	Ω	2.20	5	28	45	70	100	180
Max. thermal load	I_{th}	A	0.50	0.55	0.35	0.25	0.22	0.18	0.14
Max. allowed speed	n_a	Rpm	8 000	8 000	8 000	8 000	7 500	6 000	5 000

BRUSHES

GRADE	CODE	APPLICATION LIMITS	DIMENSIONS	NUMBER
CA – Silver-graphite		300 V	6 x 4 x 13 mm	4

PRODUCT DESCRIPTION

TG-RE-0315L B 1x60 CA IP44 6x14

