

## EML-SR

### SINGLE TURN MAGNETIC SENSOR 角度感測器

- Long Life 高迴轉壽命:  $1 \times 10^9$  cycles
- Output Type 輸出種類: 4-20 mA
- 0-5V / 0-10V

- High Resolution 高解析值:  $\pm 0.1\%FS$
- Application 適合: 角度 Angle、位置 Position
- 張力 Tension、速度 Speed

## DIMENSION

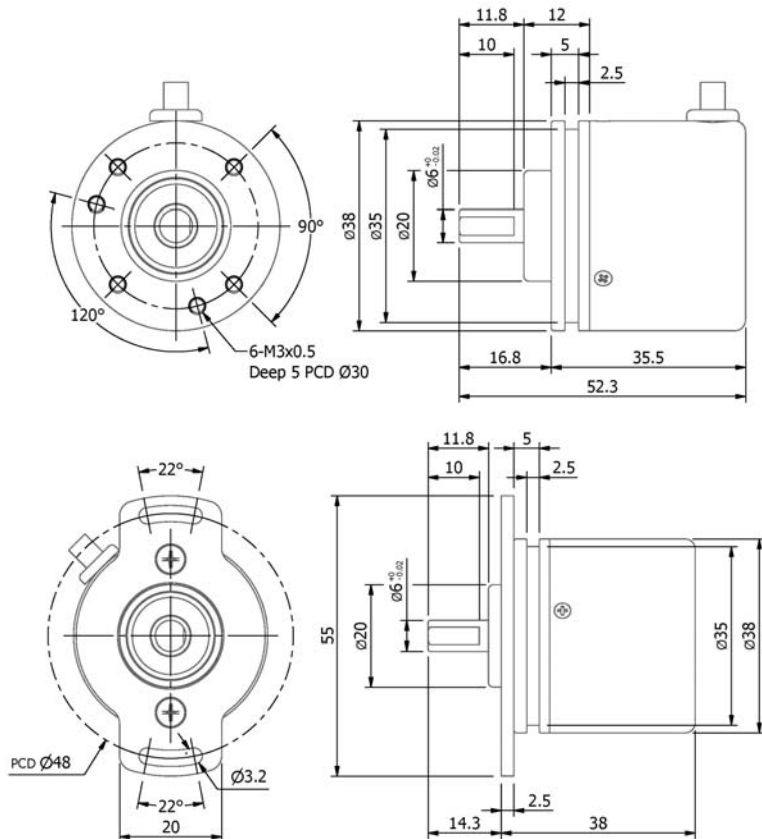

EML-SR



EML-SR1

## ELECTRICAL SPEC.

Power Supply 供應電源	DC 10~30V
Output Type 輸出信號	4-20 mA / 0-5V / 0-10V
Resolution 分解度	$\pm 0.1\%FS$
Output Tolerance 輸出誤差	$\pm 0.1\%FS$
Output Loading 輸出負載	(4-20 mA) $RL \leq 750\Omega$ (0-5V/10V) $RL \geq 10K\Omega$
Dielectric Strength 絕緣電壓(Vrms)	1KV / min.
Dielectric Resistance 絕緣電阻(MΩ min.)	100 M / 500 Vdc
Temp. Coefficient 溫度系數(ppm/°C)	250 ppm/°C

## MECHANICAL SPEC.

Shaft Diameter 軸徑	6 mm
Mechanical Angle 機械迴轉角度	360° continuous 連續
容許迴轉數(rpm)	1000 rpm
Mechanical Life 機械迴轉壽命	$1 \times 10^9$ cycles
Cable 電線	Ø4.5, 1 m long
Weight 重量	< 200 g

## ENVIRONMENTAL SPEC.

Operating Temp. 容許操作溫度	-20°C ~ 60°C
------------------------	--------------

## OUTPUT CURVE

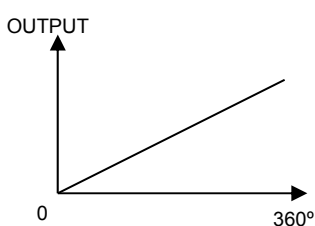

## CONNECTION

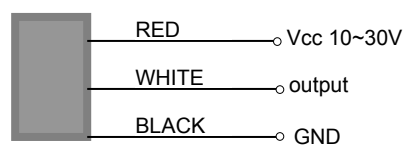

## ORDERING INFORMATION

EML-SR-	
EML-SR1	Signal Output 輸出信號
	420: 4-20 mA
	5V: 0-5V
	10V: 0-10V